

Tempest Deicer XR Boom

The Model of Efficiency

The JBT AeroTech Tempest XR aircraft deicer with the extended reach boom offers the most efficient solution for deicing the A-380 and IL-76 aircraft.

Unlike other extended reach deicers the Tempest XR does not require a special chassis or outriggers. That is because the XR boom is mounted on the standard Tempest chassis and when in the non-extended mode operates with the same characteristics as the standard boom. When extended to a height of 17.2 m (56 ft) the Tempest can safely and effectively spray the tail section of the A-380 and the IL-76 with a spray reach of 27 m (90 ft).

Designed with a 5:1 factor of safety that is validated with FEA and strain gauge testing, the Tempest XR boom can be driven in creep mode with the boom fully extended adding flexibility and providing faster deicer operations. Operation and controls are identical to those on the standard Tempests reducing the time needed for additional training. The Tempest custom chassis with a low profile design and short turning radius offers excellent maneuvering in tight areas, dynamic braking for safe stopping and a chassis cab with minimal blind spots.

The Tempest XR is available with either an open or enclosed basket, along with optional AirFirst® forced air, proportional mix and one person drive.



Tempest Deicer XR Boom

The Tempest XR provides the following benefits:

- Efficiently and safely services all commercial aircraft types including the A-380 and IL-76
- Faster operations with no outriggers required
- Short turning radius for tight areas with compact chassis
- Smoother and safer stopping with dynamic braking
- Choice of open or enclosed basket to meet operational requirements
- Same operating characteristics as the standard Tempest
- Cost savings realized with AirFirst, proportional mix and one man drive options
- Flexibility to be used as an aircraft washer

XR Specification:

Telescopic Boom Section Basket:

Max. Height 17.2 m (56 ft)
 Max. Side Reach 10.7 m (35 ft)
 Rotation 350° non-continuous

Boom Capacity:

Open Basket 204 kg (450 lb)
 Enclosed Basket 136 kg (300 lb)

Spray Height 27 m (90 ft)
 Max. Speed with XR Boom Extended 6.4 k/hr (4 mph)

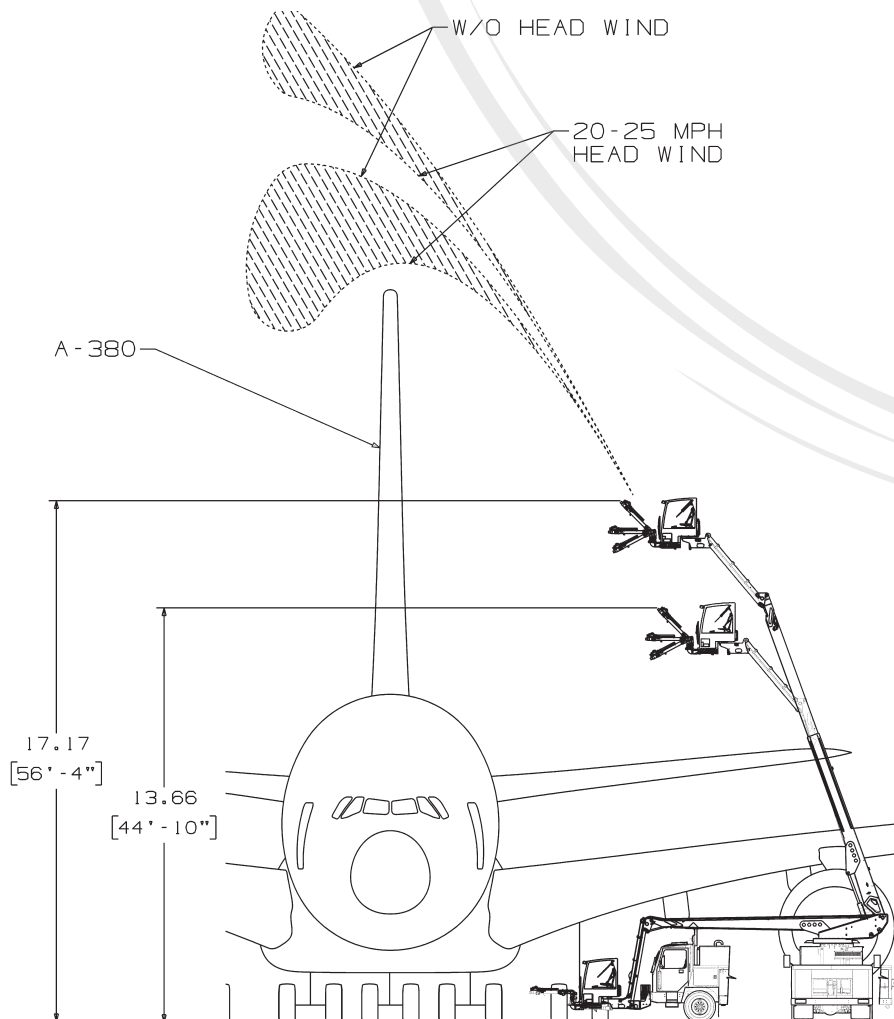

Precise boom controls

The Tempest XR uses a closed loop control system which automatically retracts the boom as it is lowered. This allows the deicer to operate with maximum side reach at any height without compromising stability. The use of a counterweight at the base of the boom further ensures stability even when the boom is lowered manually without the closed loop controls.

www.jbtaerotech.com

USA

7300 Presidents Drive
 Orlando, FL 32809
 USA
 Phone: +1 407 851 3377
 Fax: +1 407 850 2839
jbtaerotech.gse@jbt.com

Spain

A-2, Km 34 400
 28805 Alcala de Henares
 Madrid, Spain
 Phone: +34 91 8775 880
 Fax: +34 91 8775 881

UK

658 River Gardens
 North Feltham Trading Est.
 Feltham, London Heathrow
 Middx, TW14 0RB, UK
 Phone: +44 20 8587 0666
 Fax: +44 20 8587 0660

Singapore

6 Loyang Lane #03-00
 Young Heng Industrial Building
 Singapore 508920
 Phone: +65 6542 9255
 Fax: +65 6542 7493